

1. Transpiration is the loss of water from plants by evaporation. The diagram below shows a potometer, an apparatus used to **estimate** transpiration rates.

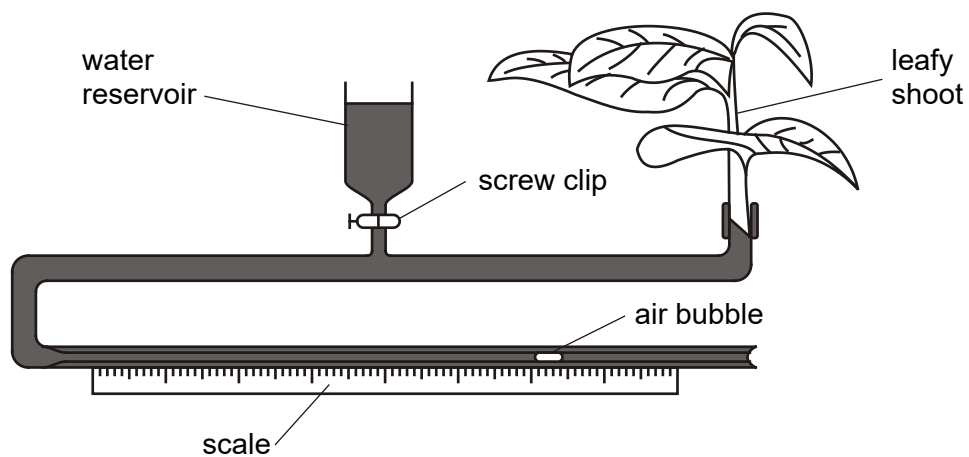

- (a) Transpiration itself is not measured directly by a potometer.

State what is measured by this apparatus.

.....

[1]

- (b) Describe how the apparatus should be set up to ensure that valid measurements can be made.



In your answer, you should make clear how the steps in the process are sequenced.

(Allow one lined page).

[7]

[Total 8 marks]

2. A student investigated the transpiration rates of two different plants **A** and **B**.

The results of the investigation are shown in the table below.

reading	estimate of transpiration rate / arbitrary units	
	plant A	plant B
1	45	107
2	39	99
3	41	106
4	46	101
5	38	103
mean	42	

- (i) Calculate the mean estimated transpiration rate for plant **B**.

Express your answer to the nearest whole number and write it in the shaded box in the table.

[1]

- (ii) The student prepared a temporary slide of a transverse section through one of the leaves. The figure below shows a diagram the student drew of the **lower epidermis** from one of the leaves.

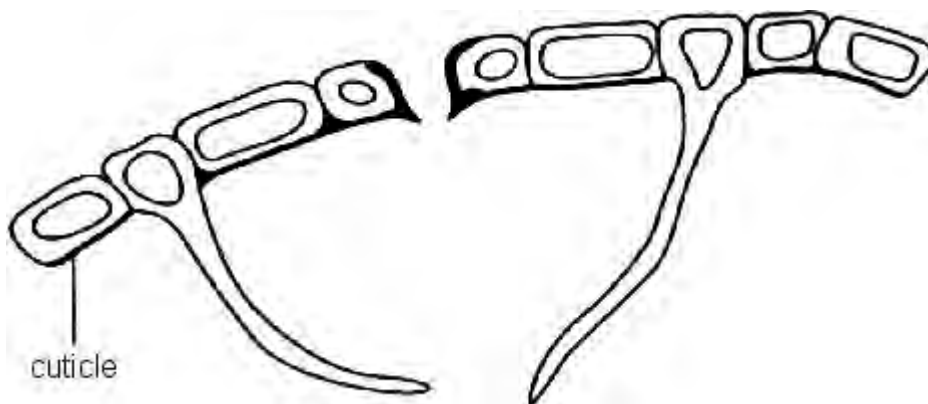

State from which plant, **A** or **B**, the leaf was taken. Explain your answer.

Plant



Explanation

.....
.....
.....

[3]

[Total 4 marks]

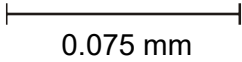
3. A student was studying the surface area to volume ratio of three unicellular organisms, **A**, **B** and **C**, from the same habitat. The diagram below shows the three organisms and some of the calculations the student made.

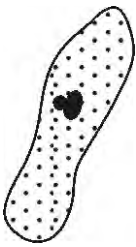
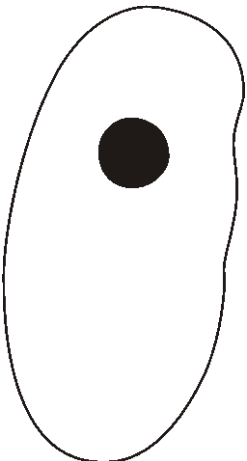
scale:  0.075 mm	A	B	C	
				
	surface area / mm ²	0.28	3.1	23
	volume / mm ³	0.02	0.59	11.3
surface area to volume ratio	14:1		2:1	

Adapted data © M Jones and G Jones, *Advanced Biology*, 1997, Cambridge University Press

- (a) (i) Calculate the surface area to volume ratio for organism **B** to the nearest whole number.

Write your answer in the shaded box in the table.

[1]

- (ii) By how many times does the surface area to volume ratio for organism **C** differ from that for organism **A**?

.....

[1]

(b) The student determined the rate of oxygen uptake for the three organisms in cm^3 of oxygen $\text{g}^{-1} \text{h}^{-1}$. The student found that the results were:

$1.0 \text{ cm}^3 \text{ g}^{-1} \text{ h}^{-1}$

$0.5 \text{ cm}^3 \text{ g}^{-1} \text{ h}^{-1}$

$7.0 \text{ cm}^3 \text{ g}^{-1} \text{ h}^{-1}$

State which of the three figures is most likely to be the value for the rate of oxygen uptake for **organism C**.

.....

[1]

(c) None of the organisms **A**, **B** or **C** has a transport system.

Explain why organisms larger than organism **C** need to have transport systems.

.....
.....
.....
.....
.....
.....

[3]

[Total 6 marks]

4. Transpiration may be defined as the loss of water vapour by diffusion from a plant to its environment.

The diagram below shows apparatus that can be used to estimate transpiration rates of a leafy shoot.

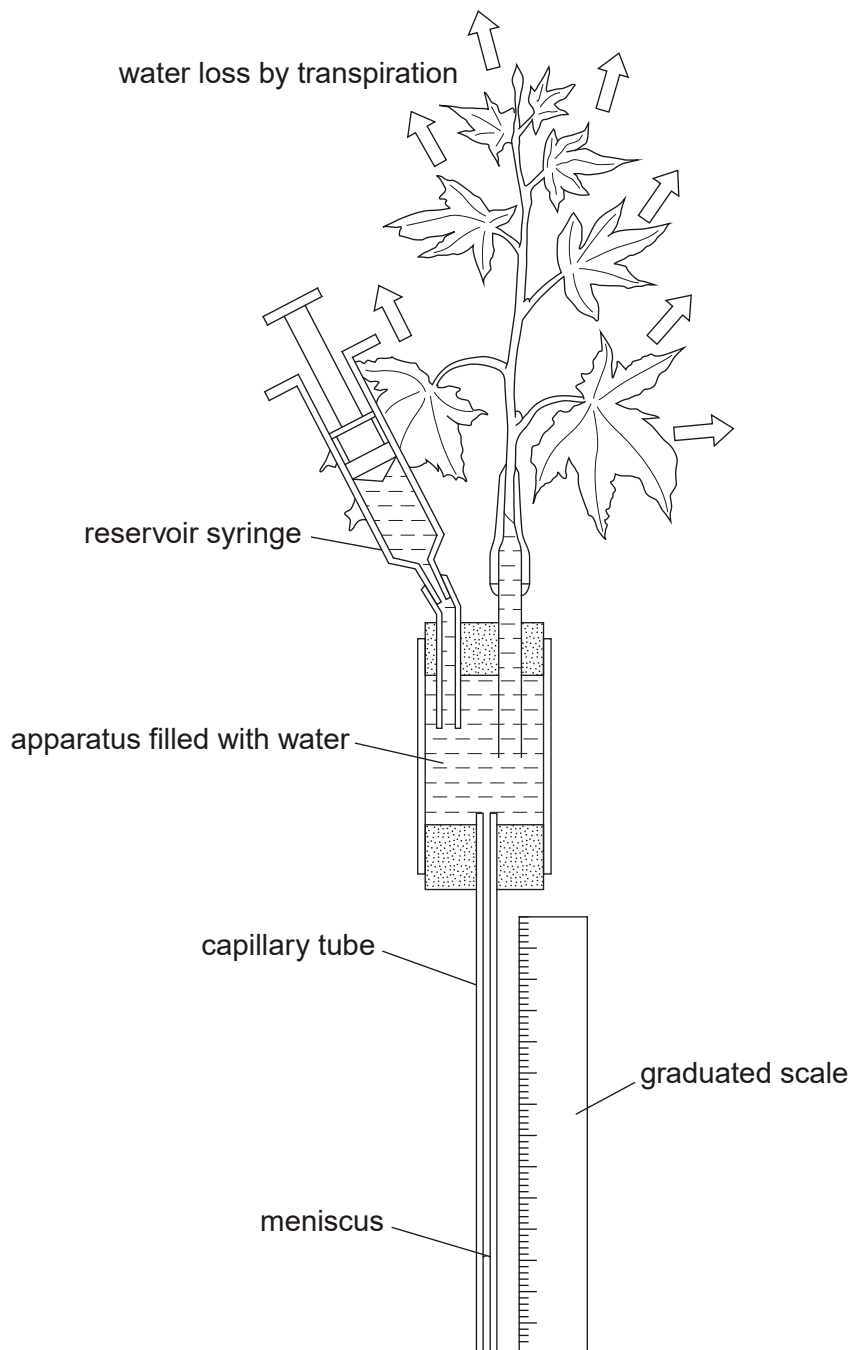

- (i) State the name of the apparatus shown in the diagram.

.....

- (ii) A student was told that any results gained by using the apparatus shown in the diagram above are not measures of the actual transpiration rate, but only give values from which transpiration can be **estimated**.

With reference to the definition of transpiration **and** the apparatus in the diagram above, explain why the results gained by using the apparatus are **not** measures of the actual transpiration rate.

.....

.....

.....

.....

.....

.....

.....

[3]

- (iii) Describe the precautions you would take when setting up and using the apparatus shown in the diagram above in order to get valid readings from which the transpiration rate can be estimated.

.....

.....

.....

.....

.....

.....

.....

.....

[4]

[Total 8 marks]

5. The diagram below shows the results gained from an experiment to compare the rates of transpiration in two species, **P** and **Q**. Both species were kept under the same conditions during the course of the experiment.

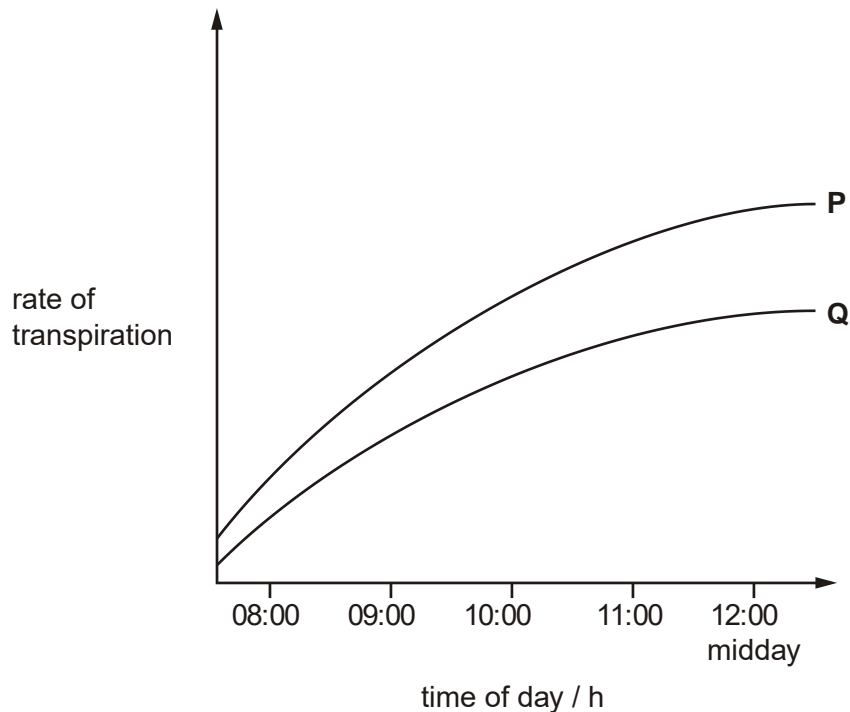

- (i) Give **two** possible explanations for the increase in the rate of transpiration in **both** species **P** and **Q** over the course of the experiment.

1

.....

.....

.....

.....

2

.....

.....

.....

.....

- (ii) Species **P** has smaller leaves than species **Q**. The student had predicted that the rate of transpiration would be **lower** in **P** than in **Q** due to its smaller leaves.

Suggest and explain one possible reason why the results are **not** as the student predicted.

.....

.....

.....

.....

[2]

[Total 6 marks]

- 6. The figure below is a diagram showing some of the cells in the root of a dicotyledonous plant.

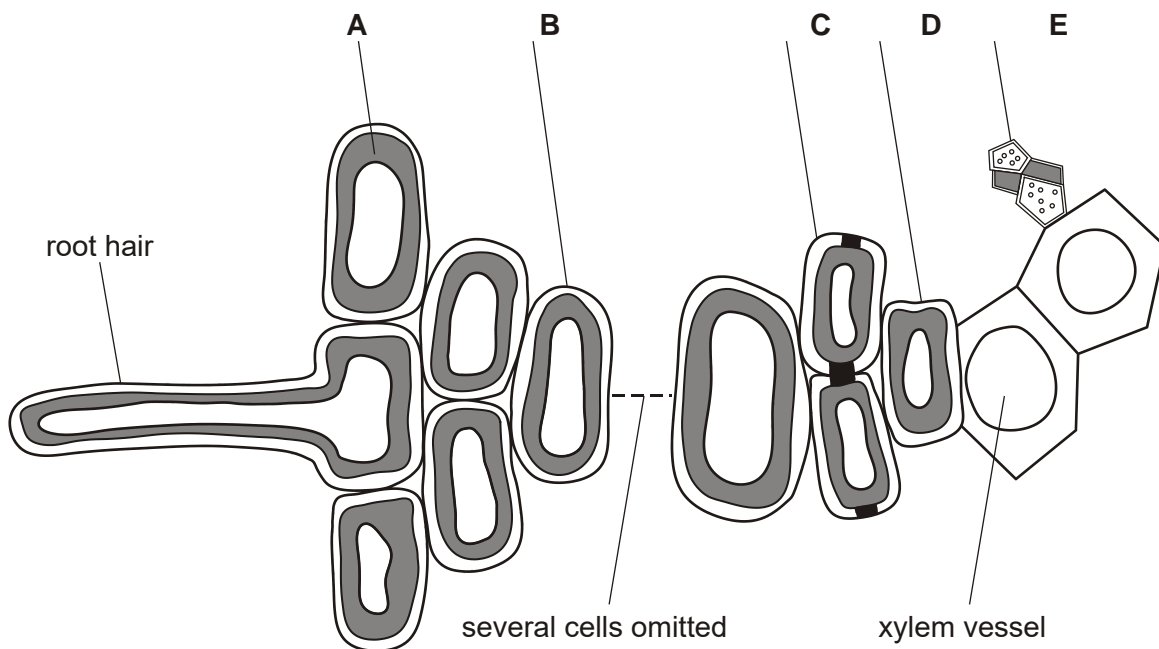

(a) Complete the table below by indicating which of the letters **A** to **E** indicates:

- a cell from the endodermis
- a cell from the phloem.

	letter
endodermis	
phloem	

[2]

(b) State **two** features of root hair cells which adapt them for water uptake.

1

2

[2]

(c) In this question, one mark is available for the quality of spelling, punctuation and grammar.

Plants absorb water from the soil via their roots.

Describe the pathways **and** mechanisms by which water passes from the soil to the xylem vessels in the root.

(Allow one lined page).

[6]

Quality of Written Communication [1]

- (d) After water has entered the xylem vessels in the root, it passes through them to the rest of the plant.

Describe how **two** features of xylem vessels adapt them for water transport.

1

.....

.....

.....

2

.....

.....

.....

[4]

[Total 15 marks]

7. The table below shows the approximate size and number of stomata in the leaves of three plant species.

The data were collected by taking photographs of pieces of leaf placed under a microscope. The length and width of a large number of stomata visible on the photographs were measured.

species	mean number of stomata per mm ² on lower epidermis	mean length of fully open stomata / μm	mean width of fully open stomata / μm	mean area available for water loss through fully open stomata / μm^2 per mm ²
<i>Phaseolus vulgaris</i> (bean)	281	7	3	5 901
<i>Hedera helix</i> (ivy)	158	11	4	6 952
<i>Triticum</i> sp. (wheat)	14	18	7	1 764

(a) (i) Explain why a large number of stomata are measured in order to calculate a mean.

.....
.....
.....
.....

[2]

(ii) Suggest **two** ways in which photographing the leaf surfaces makes measuring the stomata easier.

1

.....

2

.....

[2]

[Total 4 marks]

8. The diagram below is a vertical section through part of a leaf of a dicotyledonous plant.

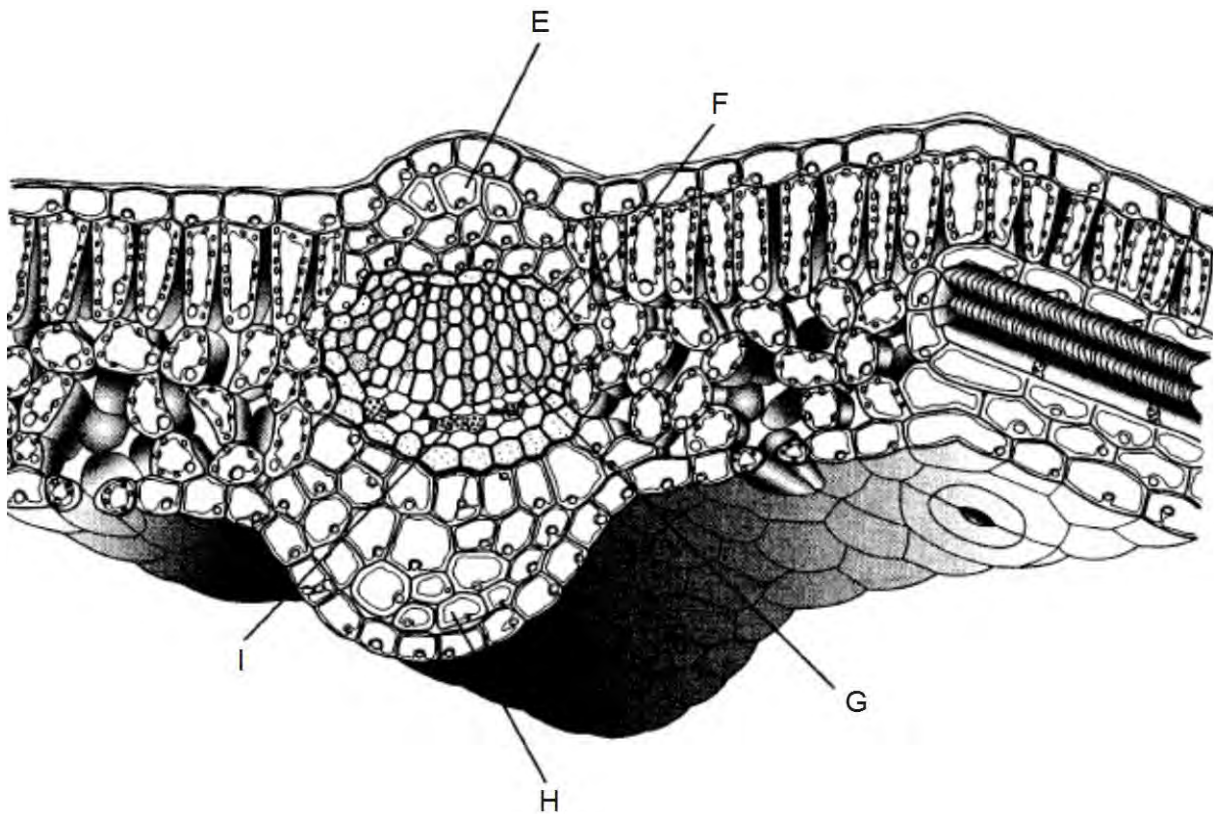

Reproduced by kind permission of D.G. Mackean

Complete the table below to identify xylem and phloem from the tissues labelled **E** to **I**.

tissue	letter
xylem	
phloem	

[Total 2 marks]

9. (i) Define the term *transpiration*.

.....
.....
.....
.....

[2]

(ii) Explain why transpiration in plants cannot be avoided.

.....
.....
.....
.....
.....
.....

[3]

- (iii) The leaves of xerophytes show a variety of modifications that are not shown in the diagram below.
For instance, they may be covered in epidermal hairs.

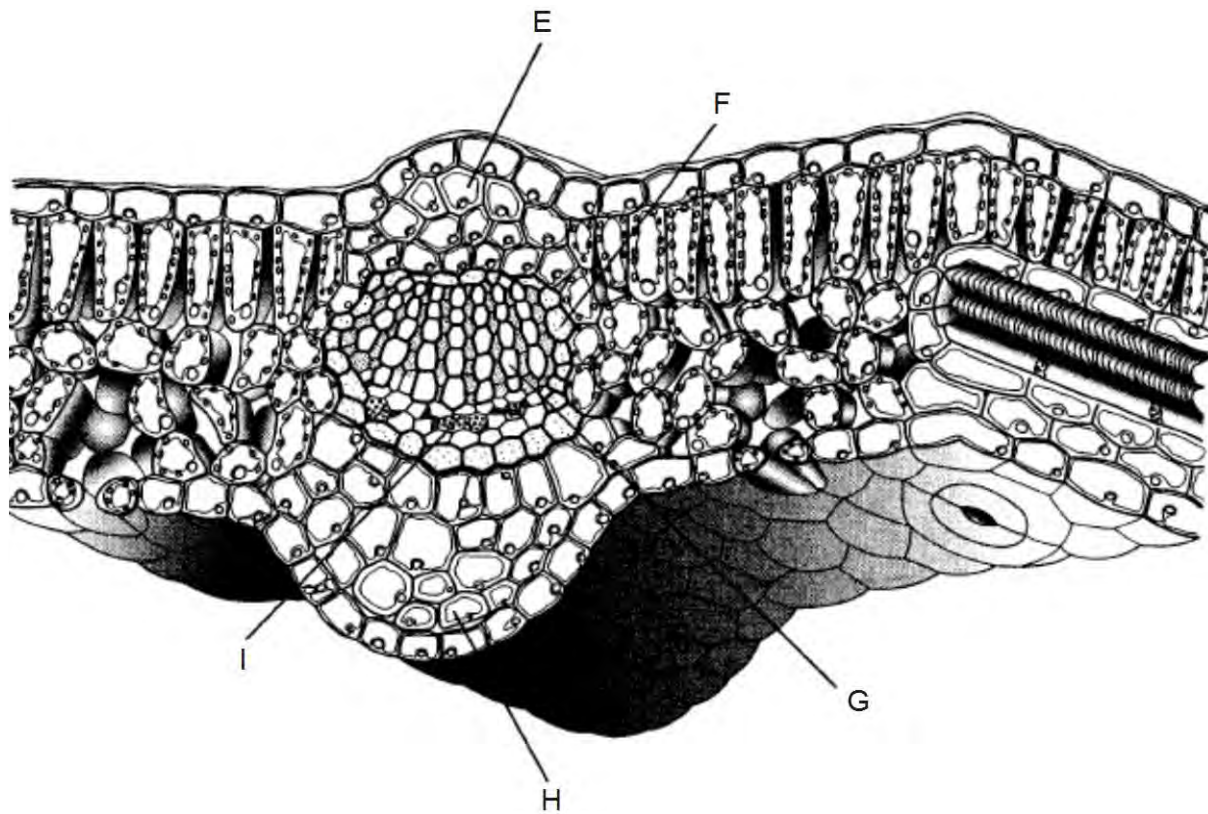

Reproduced by kind permission of D.G. Mackean

Explain how a covering of leaf epidermal hairs helps xerophytes survive in their habitat.

.....

.....

.....

.....

[2]

[Total 7 marks]

10. In this question, one mark is available for the quality of spelling, punctuation and grammar.

Explain how water travels up the stem and into the leaf of a dicotyledonous plant.

(Allow one lined page)

[6]

Quality of Written Communication [1]

[Total 7 marks]

11. Below is a diagram of a cross section of an organ from a dicotyledonous plant showing some of the tissues.

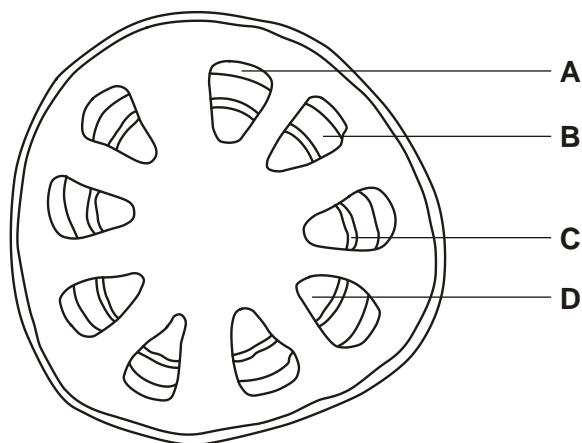

- (i) Name the plant organ shown in the diagram above.

.....

[1]

- (ii) State which of the regions **A** to **D** is phloem tissue.

.....

[1]

[Total 2 marks]

12. (a) From the list below, circle the carbohydrate that is transported in phloem.

- auxin fructose glucose glycine glycogen starch sucrose**

[1]

(b) Phloem is responsible for the transport of carbohydrate in plants. The diagram below shows the structure of the cells in phloem.

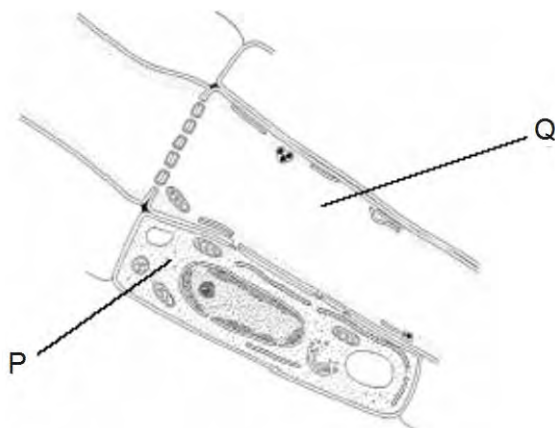

A-level Biology, page 362 Fig. 31.10A,
by W D Phillips and T J Chilton,
published by Oxford University Press,
1989. (ISBN 0 19 914089 8)

(i) Name the cells **P** and **Q** in the diagram.

P

Q

[2]

(ii) Outline how **P** and **Q** are involved in the transport of carbohydrate in phloem.

.....

.....

.....

.....

.....

.....

[3]

[Total 6 marks]

13. Carbohydrate moves from regions of plants called sources to regions called sinks.

Explain how, at different times, the same plant root may be a source or a sink.

.....

.....

.....

.....

.....

.....

[Total 2 marks]

14. Complete the following passage on water uptake by the root using the most appropriate word or words.

Water moves from the soil to the xylem in the root down a gradient.

The root hairs provide a large surface area for water uptake and once water has been taken up it crosses to the xylem by two pathways. The pathway goes via the cell walls but is blocked at the by the The other route involves the water crossing cell membranes by the process of osmosis and entering the cytoplasm. This is called the pathway.

[Total 5 marks]

15. Plants take up nitrate ions and water from the soil into the roots.

(i) State **one** way in which root hairs are adapted to increase uptake.

.....

[1]

(ii) State **one** method used by root hairs to take up nitrate ions.

.....

[1]

- (iii) Outline the process by which water enters the cells of the root from the soil.

.....

.....

.....

.....

[2]

[Total 4 marks]

16. Flowering plants have two tissues to transport materials, xylem and phloem. The diagram below shows the outline of a transverse section of the **root** of a dicotyledonous flowering plant.

Sketch in and label the areas occupied by the xylem and phloem.

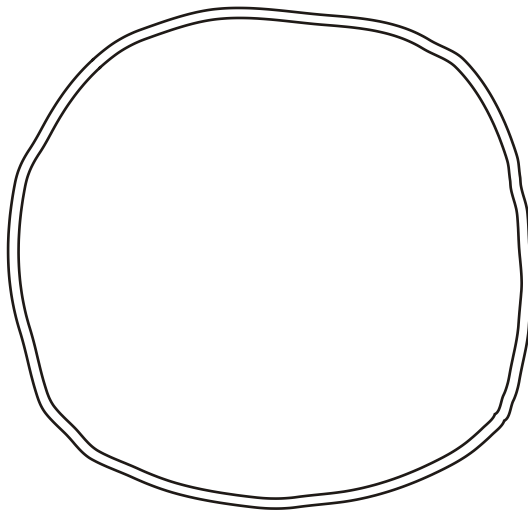

[Total 2 marks]

17. The diagram below is a scanning electron micrograph of some xylem vessels.

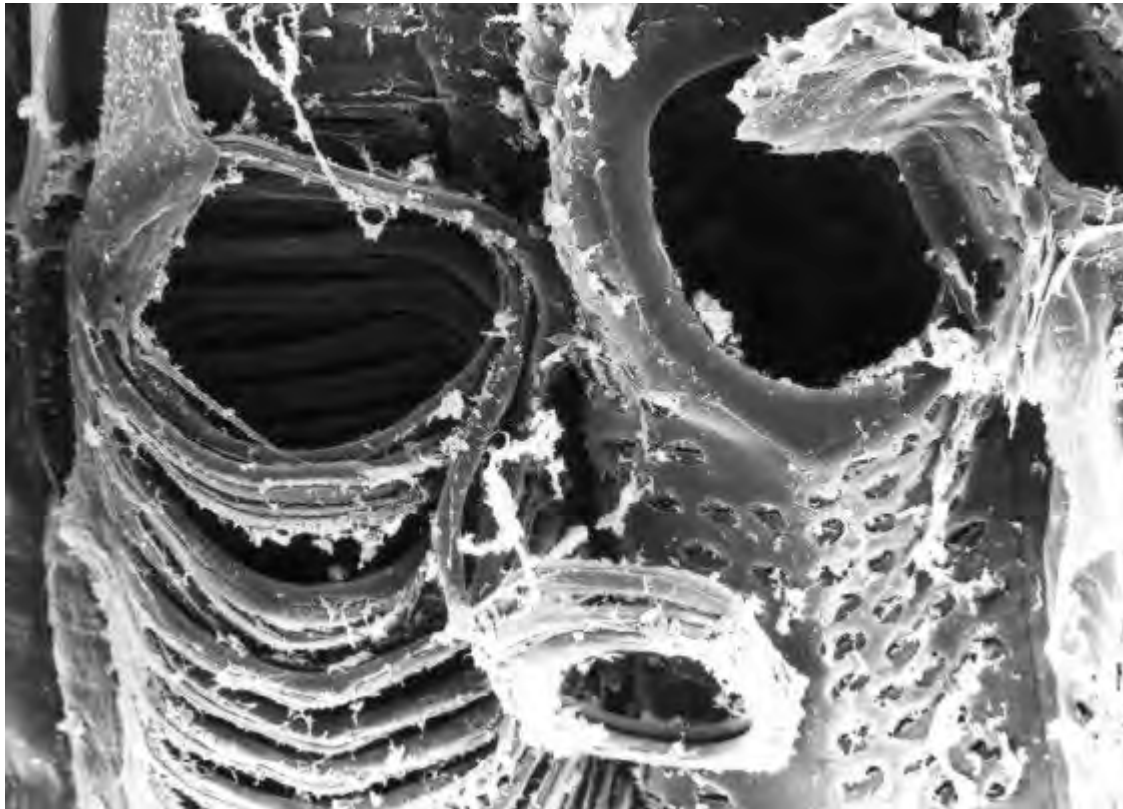

Biophoto Associates

Select **two** features **that are visible in the electron micrograph** and explain how these features help with the functioning of xylem vessels.

feature 1

.....
.....
.....

feature 2

.....
.....
.....

[Total 4 marks]

18. Various hypotheses for the mechanism of transport in phloem have been suggested. One hypothesis proposes that movement between sources and sinks occurs entirely passively by the process of mass flow.

The diagram below shows a physical model to illustrate the principle of mass flow.

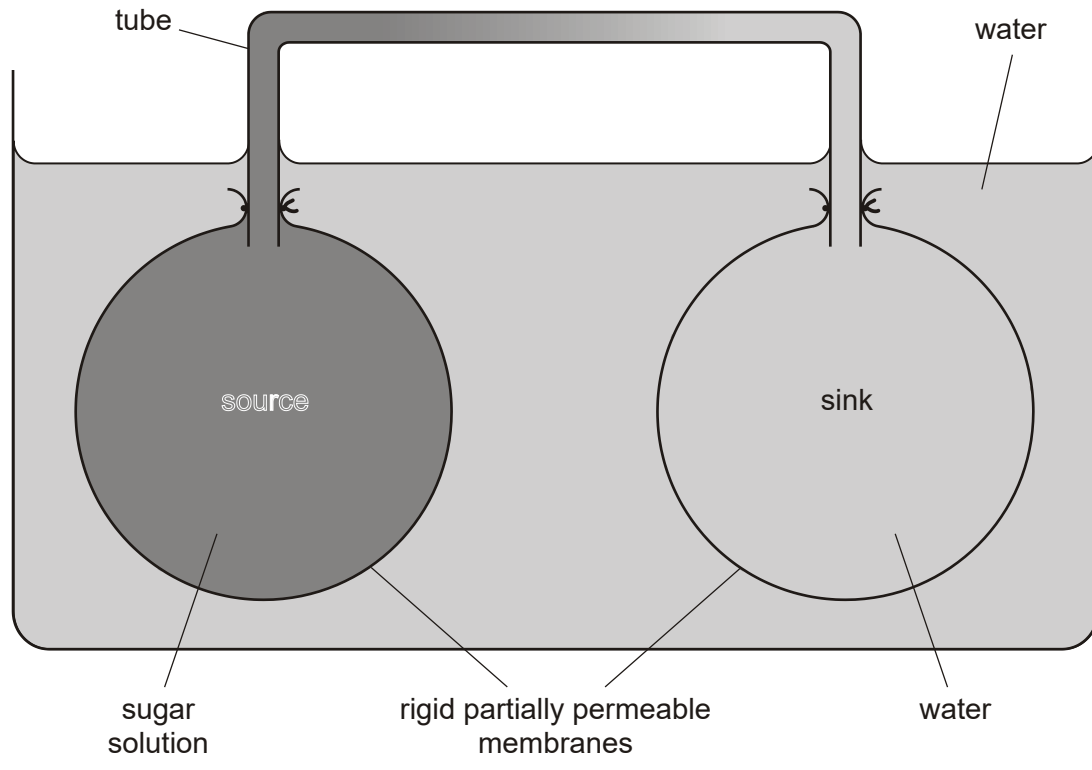

- (i) Give an example in plants of:
 a source
 a sink

- (ii) Use the information in the diagram to explain how mass flow of materials between the source and the sink would be brought about.

.....

.....

.....

.....

.....

.....

.....

.....

[4]

[Total 6 marks]

19. There is evidence that sugar transport from sources to sinks in plants does not only involve passive movement by mass flow. There is also an active part to the mechanism.

- (i) State **one** piece of evidence for the involvement of an active process.

.....

.....

[1]

- (ii) Describe an active mechanism which could possibly be involved in the transport of sugars from sources to sinks.

.....

.....

.....

.....

.....

.....

[3]

[Total 4 marks]

20. Transpiration is the loss of water from plants by evaporation. The diagram below shows a potometer, an apparatus used to **estimate** transpiration rates.

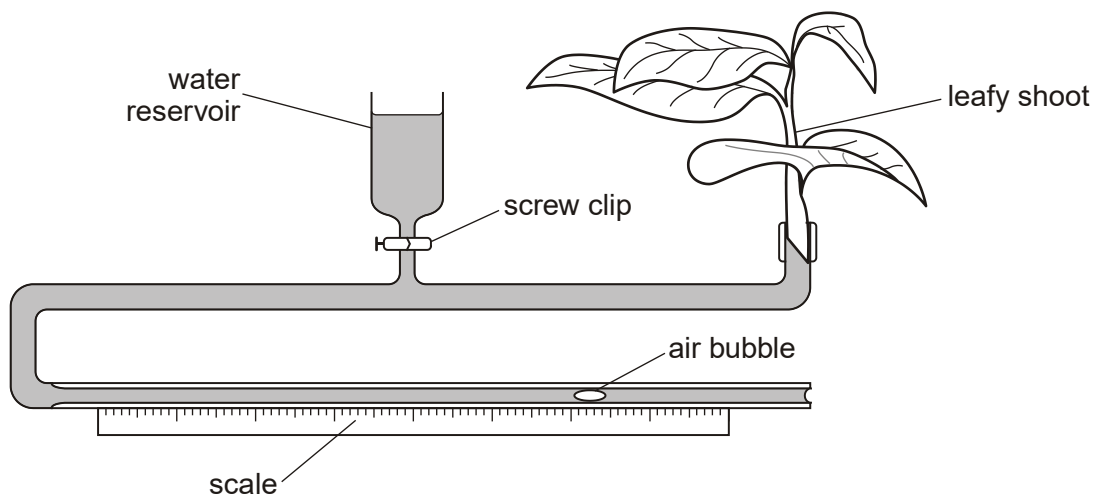

(i) Describe how the apparatus should be set up to ensure that valid measurements can be obtained.

.....

.....

.....

.....

.....

.....

.....

.....

.....

[4]

(ii) Transpiration itself is not measured by the potometer. State **precisely** what is measured by using the apparatus.

.....

.....

[1]

[Total 5 marks]

21. Transpiration is the loss of water from plants by evaporation. The diagram below shows a potometer, an apparatus used to **estimate** transpiration rates.

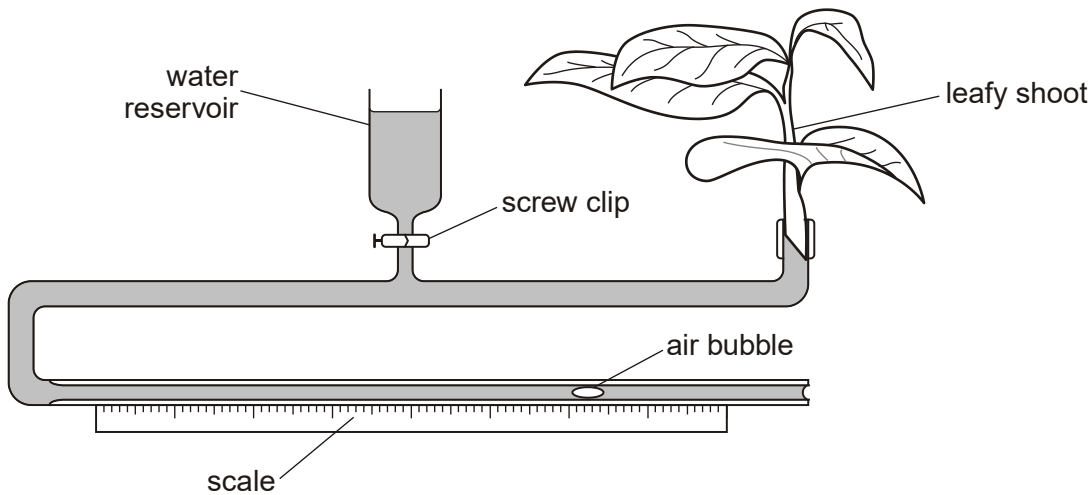

- (a) A student investigated transpiration rates of a plant under two conditions, **A** and **B**, in the laboratory using a potometer. In both cases the temperature, the humidity, and the duration were the same. A fan was placed next to the potometer and was turned on for condition **B**, but not for condition **A**.

The results are shown in the table below.

reading	estimate of transpiration rate / arbitrary units	
	condition A	condition B
1	45	107
2	39	99
3	41	106
4	46	101
5	38	103
mean	42	

- (i) Calculate the mean estimated transpiration rate for condition **B**. Express your answer **to the nearest whole number** and write it in the table above.

[1]

- (ii) Explain why the mean estimated transpiration rate for condition **B** is greater than that for condition **A**.

.....

.....

.....

.....

.....

.....

.....

[3]

- (b) The student wanted to compare the rates of transpiration of two species of plant using the potometer shown in the diagram.

Suggest what the student would need to do in order to get a valid comparison of the rates of transpiration of the two species.

.....
.....
.....
.....

[2]

[Total 6 marks]

- 22.** Xerophytes are plants that are adapted for survival in areas where there is not much water available in the soil.

Xerophytes are usually found in habitats where the soil water potential is about -50 kPa.

Explain why the cell contents of the roots of xerophytes must have a water potential lower (more negative) than -50 kPa if the plants are to survive in these habitats.

.....
.....
.....
.....

[Total 2 marks]

23. Xerophytes are plants that are adapted for survival in areas where there is not much water available in the soil.

Xerophytes have various modifications that reduce water loss from their leaves.

State **two** such adaptations that reduce water loss **and** explain how the reduction in loss is achieved.

adaptation 1

.....

.....

adaptation 2

.....

.....

[Total 4 marks]

24. Fig. 1 shows the distribution of some of the tissues in a transverse section of a plant organ. Fig. 2 is a photograph showing details of two cells, **D** and **E**, from one of the tissues.

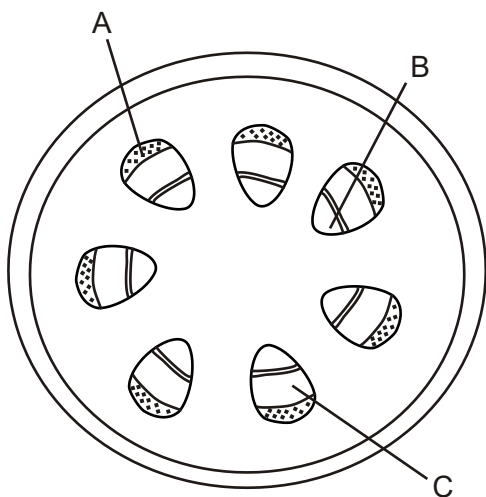

Fig. 1

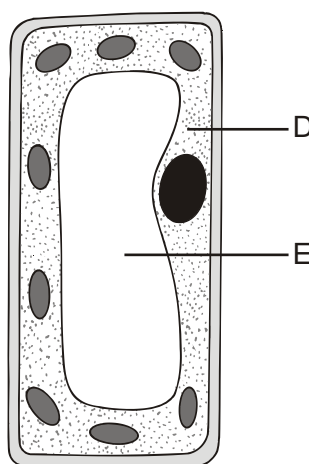

Fig. 2

(a) Name the plant organ shown in Fig. 1

.....

[1]

(b) Name the tissue shown in Fig. 2.

.....

[1]

(c) State in which region, **A** to **C** of Fig. 1, you would expect to find the tissue shown in Fig. 2.

.....

[1]

(d) Complete the table below by:

- **stating three** features or properties of cells **D** or **E** in Fig. 2 which adapt them to their function;
- **explaining** how the features or properties you have given help the tissue to carry out its function.

Make it clear in your answer which cell, **D** or **E**, you are describing for each feature you give.

feature or property	how the feature or property helps the tissue to carry out its function

[6]

[Total 9 marks]

25. The photograph below shows some plants growing in desert conditions. Such plants are known as xerophytes.



Suggest how each of the following features of xerophytic plants helps them to survive in their habitat.

(a) The stomata are shut during the day and open at night.

.....

.....

.....

(b) The leaves of some plants are reduced to spines or needles.

.....
.....
.....

(c) The epidermis may be covered by hairs.

.....
.....
.....

[Total 6 marks]

26. The graph below shows the results of an investigation to compare rates of transpiration and water absorption by a plant during a hot day in summer. There was no shortage of soil water available to the plant throughout the investigation, which was carried out over 24 hours starting at midnight.

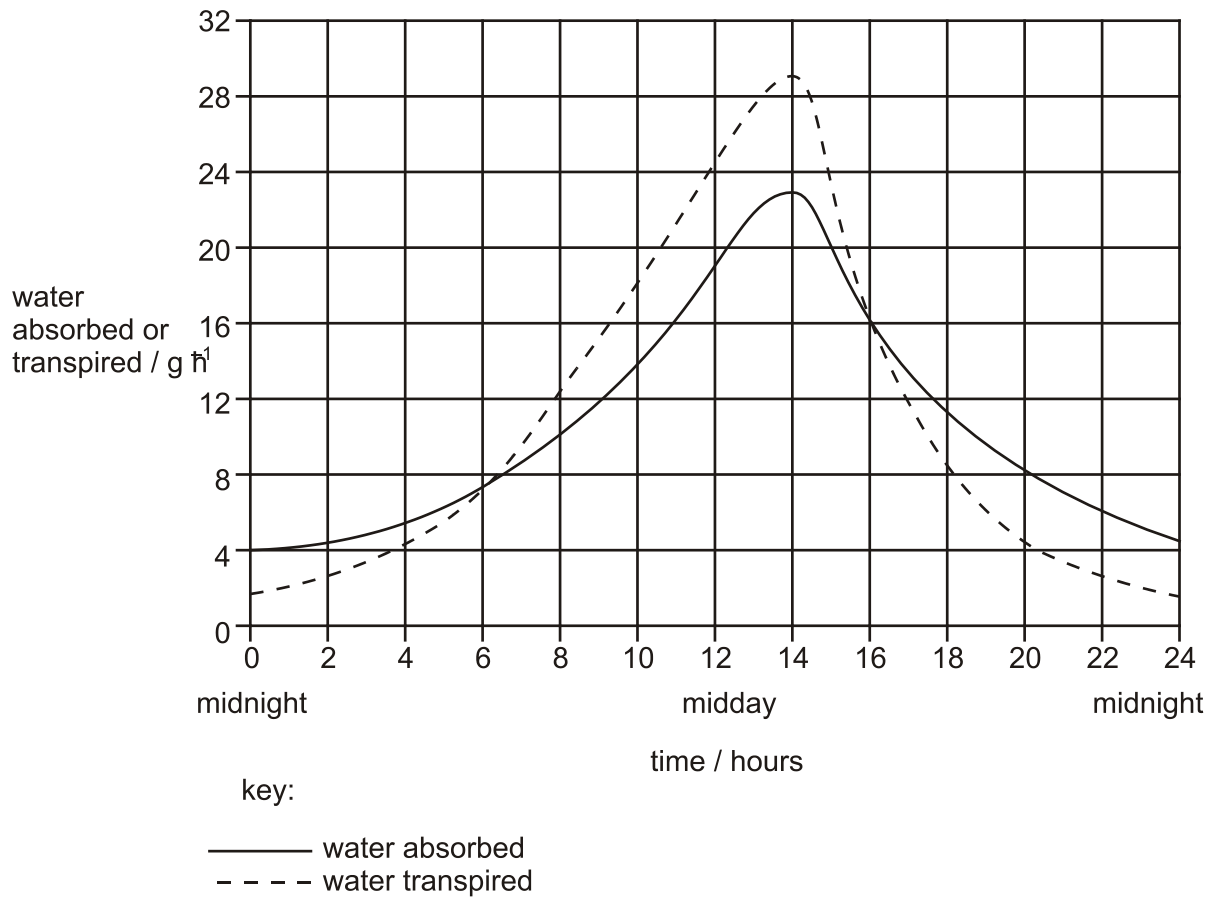

(i) Define the term *transpiration*.

.....

.....

.....

.....

- (ii) Using the graph above, describe how the rate of transpiration varied over the 24 hour period **and** compare it with the rate of water absorption.

.....

.....

.....

.....

.....

.....

.....

.....

[4]

- (iii) Calculate the percentage of the 24 hour day in which the rate of water absorption exceeds the rate of transpiration.

Show your working and **give your answer to the nearest whole number.**

Answer %

[2]

[Total 8 marks]

27. Explain how transpiration results in the movement of water up a plant stem.

.....

.....

.....

.....

.....

.....

.....

.....

.....

[Total 4 marks]